



***motoalliance***



**FIRESTORM**  
C A B H E A T E R S

**Polaris RZR 900/900S**  
**HT\_CU\_406-900**

INSTALLATION INSTRUCTIONS

**PARTS LIST**

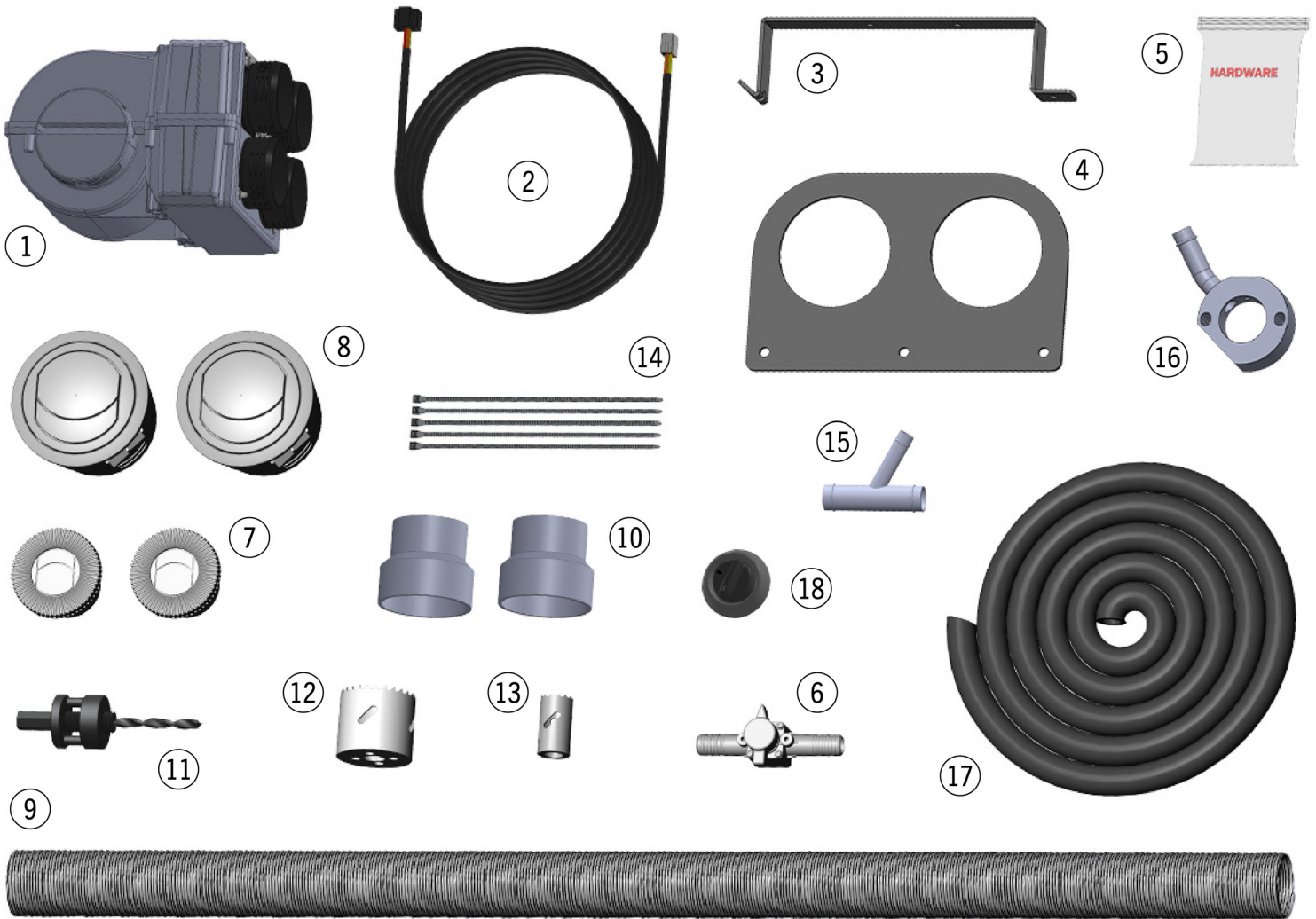

Part#	Qty	Item Description
1	1	FIRESTORM Cab Heater Unit
2	1	36" Wiring Harness
		Orange/Yellow/Black Wire
		Red Wire
		Black Wire
		5-Pin Black Connector
		4-Pin White Connector
3	1	HT_CU_499-1 Heater Mount Bracket
4	1	HT_CU_499-2 Vent Mount Bracket
5	1	Hardware Pack
	2	Rubber Grommet

Part#	Qty	Item Description
2	2	M6-1.0x12mm Hex Head Cap Screw
2	2	M6 Flat Washers
2	2	Self-tapping Plastic Screw
3	1	1/4"-20x3/4" Serrated Flange Bolt
3	1	1/4"-20 Serrated Flange Nut
2	2	Insulation Displacement Crimp
8	2	#10 Stainless Steel Hose Clamps
2	2	#16 Stainless Steel Hose Clamps
6	1	Plastic Shut-Off Valve
7	2	2" Vent
8	2	3" Vent

Part#	Qty	Item Description
9	24"	2" Compressed Duct Hose
10	2	2"-2.5" Stepdowns
11	1	Hole Saw Pilot Bit
12	1	2" Hole Saw
13	1	1 1/4" Hole Saw
14	20	Zip Ties
15	1	1" Aluminum Y
16	1	Thermostat Bypass Valve BP102
17	20'	5/8" Coolant Hose
18	1	3-Position Switch



Please read all instructions before beginning installation. Verify that all parts listed are present.

We have found that several steps in this installation are easier with two people. We recommend finding a partner to assist with this installation.



When working on cooling systems, always allow vehicles to cool to avoid being burned or scalded by hot coolant.

Before working with any electrical system on your vehicle, **ALWAYS** remove the negative battery cable and secure it away from the battery terminal.

## PREPARATION

1. Remove the bottom skid plate panels with a socket wrench. *FIGURE 1*



*FIGURE 1*

2. Remove the front windshield, if applicable.
3. Completely remove the front dash and set aside.

4. Remove all electrical connections. *FIGURE 2*

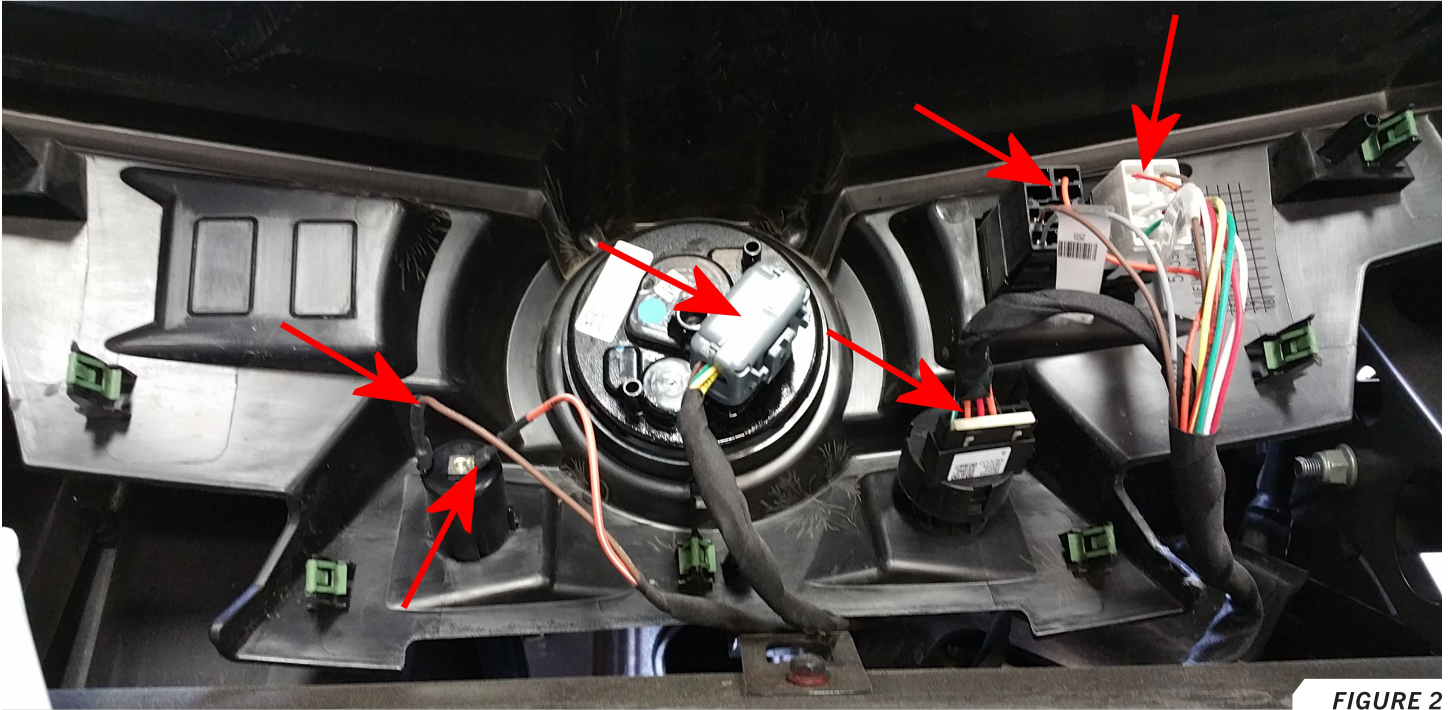

*FIGURE 2*

5. Attach the heater mounting bracket to the heater unit using the supplied M6 hardware. *FIGURE 3*



*FIGURE 3*

## CAB HEATER & DUCT HOSE INSTALLATION

6. Place the heater and bracket assembly into the dash area. *FIGURE 4*

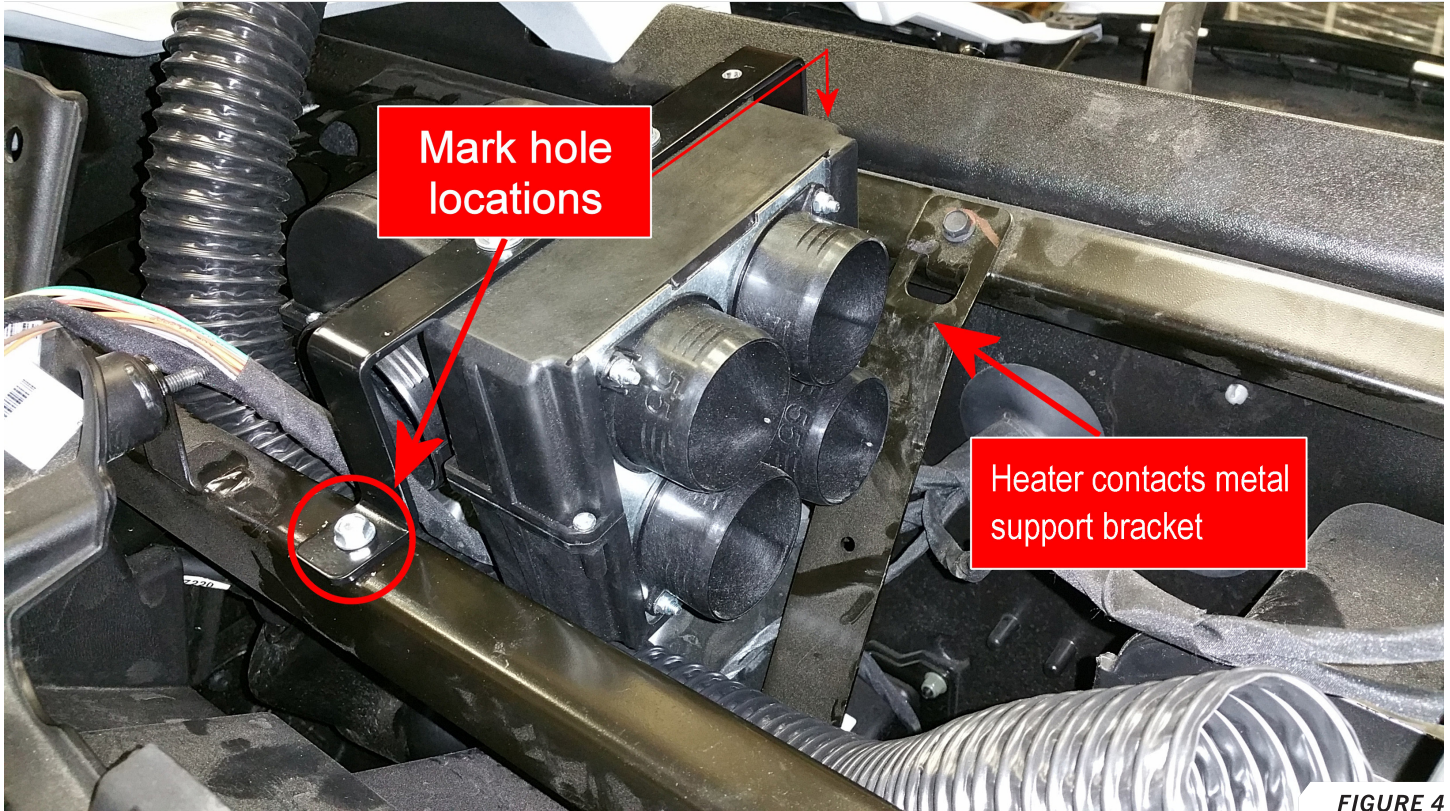

7. Rest the ends of the heater bracket on the metal dash bar and the angled surface toward the front of the vehicle.
8. Move the heater toward the center of the vehicle until it contacts the metal support bracket.
9. Ensure the heater bracket is perpendicular to the dash bar and mark the hole locations as shown in *FIGURE 4*.
10. Remove the heater and drill two  $\frac{3}{16}$ " pilot holes.
11. Reinstall the heater and attach it to the frame using the supplied  $\frac{1}{4}$ " self-tapping screws.
12. Cut the supplied 2" duct hose into the following sections: **8" (qty. 1), 5" (qty. 3)**.

13. Use a wire cutter to slit three ribs of the 8" section of 2" duct hose to allow the hose to fit over the 55mm ports. *FIGURE 5*

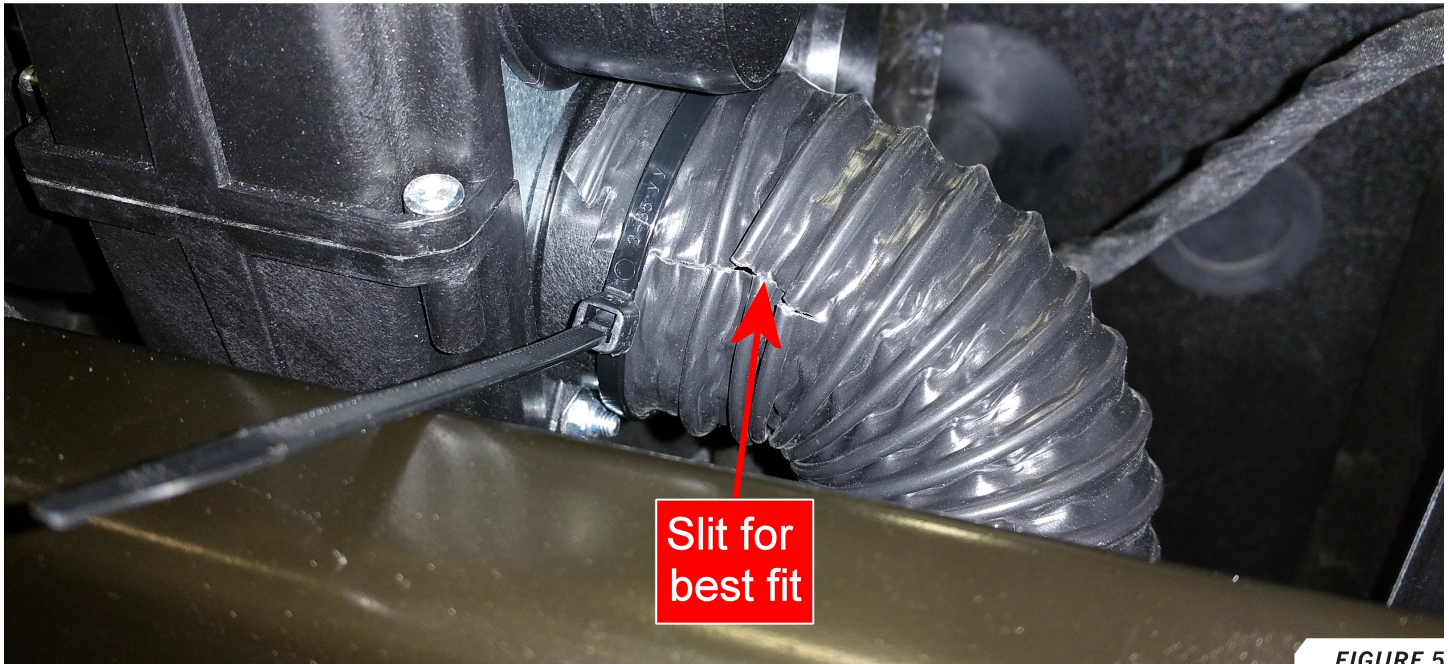

14. Attach and route the 8" section of 2" duct hose to the lower left heater vent port (as shown in *FIGURE 6*). Secure using zip ties.



15. Attach two 5" sections of 2" duct hose to the lower right and upper right heater vent ports and secure using zip ties. Use the same slit process as mentioned previously. Lower the hoses down into the cab of the vehicle. These will attach to in-cab 3" vents.
16. Attach the last 5" section of 2" duct hose to the upper left vent port. Let this hose rest on the dash area. It will be routed to the passenger side defrost vent later.
17. Cut out template #1 and template #2 and tape them to the top of the dash as shown in *FIGURE 7*.

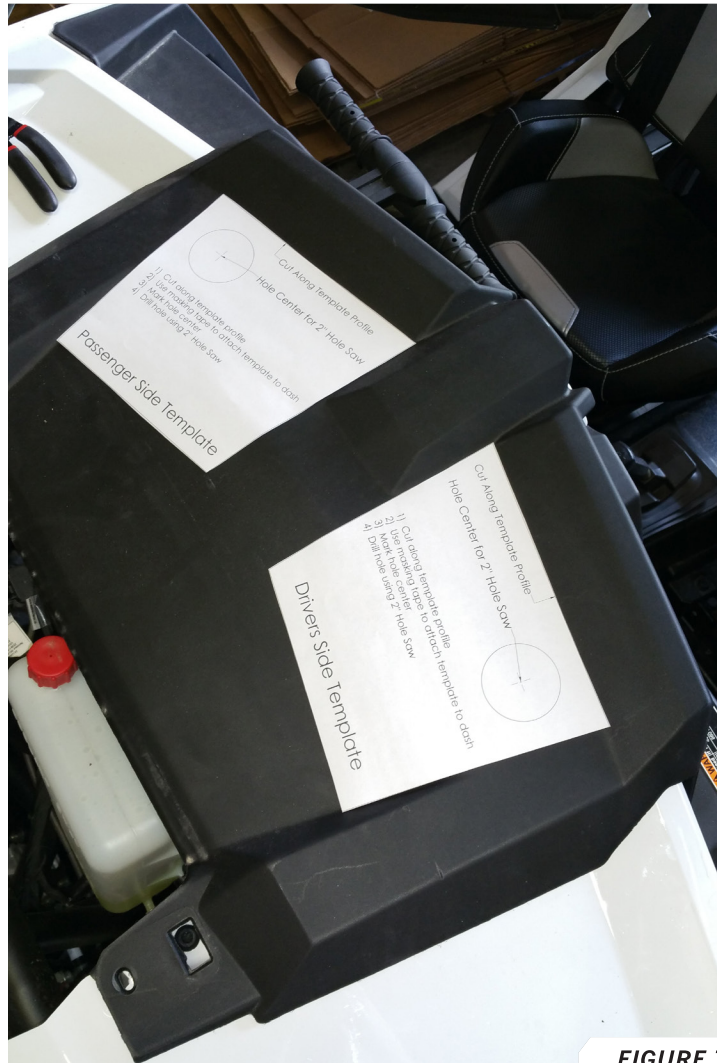

**FIGURE 7**

18. Use the pilot bit and 2" hole saw to drill the defrost vent holes. Deburr as necessary.

## IN-CAB VENT INSTALLATION

19. Cut out template #3 and tape it to the lower part of the center console as shown in *FIGURE 8*.

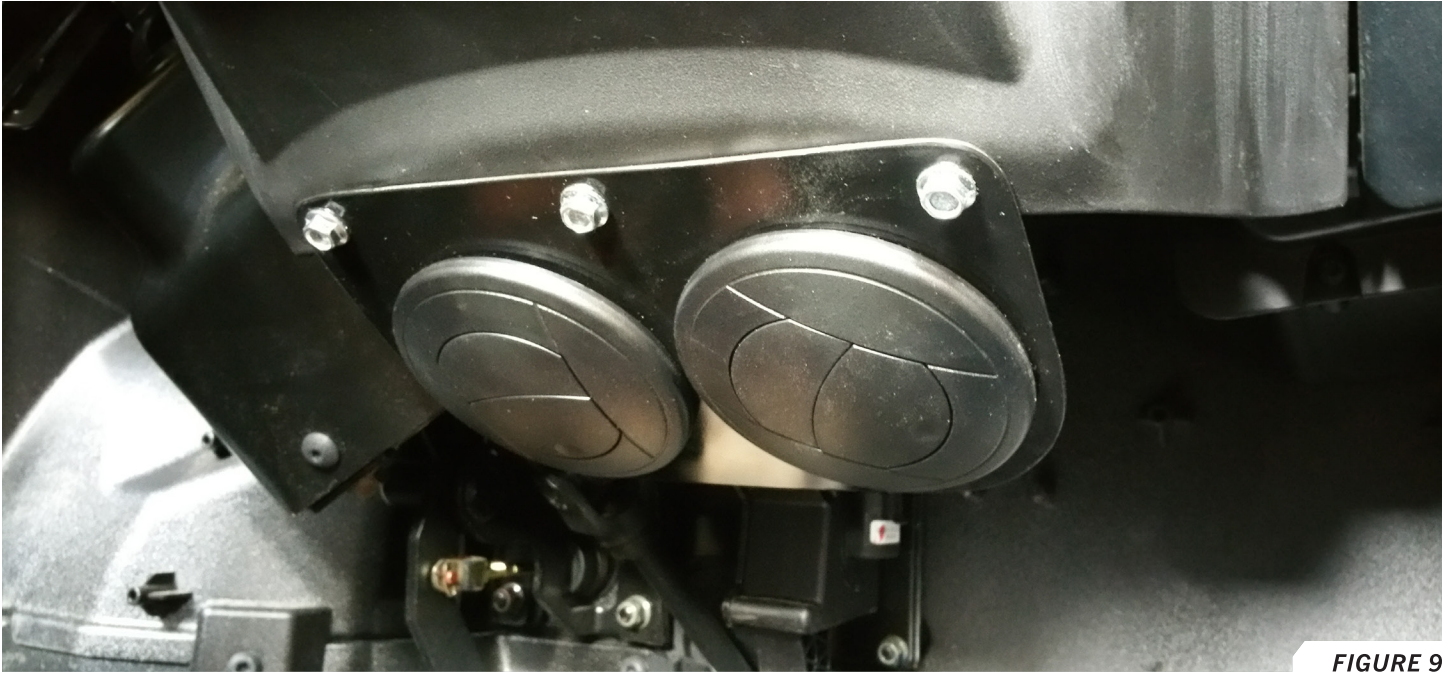

*FIGURE 8*

20. Once aligned with the edge of the center console, mark and drill the three  $\frac{5}{16}$ " holes.
21. Attach the vent bracket to the center console using the three supplied  $\frac{1}{4}$ " serrated flange bolts and  $\frac{1}{4}$ " serrated flange nuts.
22. Attach the two 2"-2.5" stepdowns to the two 3" vents. Ensure that they are securely attached.
23. Pull the two sets of duct hose that were previously lowered into the cab through the openings in the vent bracket.
24. Attach the hose ends to the 2"-2.5" stepdowns and secure with zip ties.



25. Snap the vents into the vent bracket. *FIGURE 9*



*FIGURE 9*

### COOLANT HOSE & SHUT-OFF VALVE INSTALLATION

26. Cut out template #4 and attach it to the firewall to the left of the steering column as shown in *FIGURE 10*.

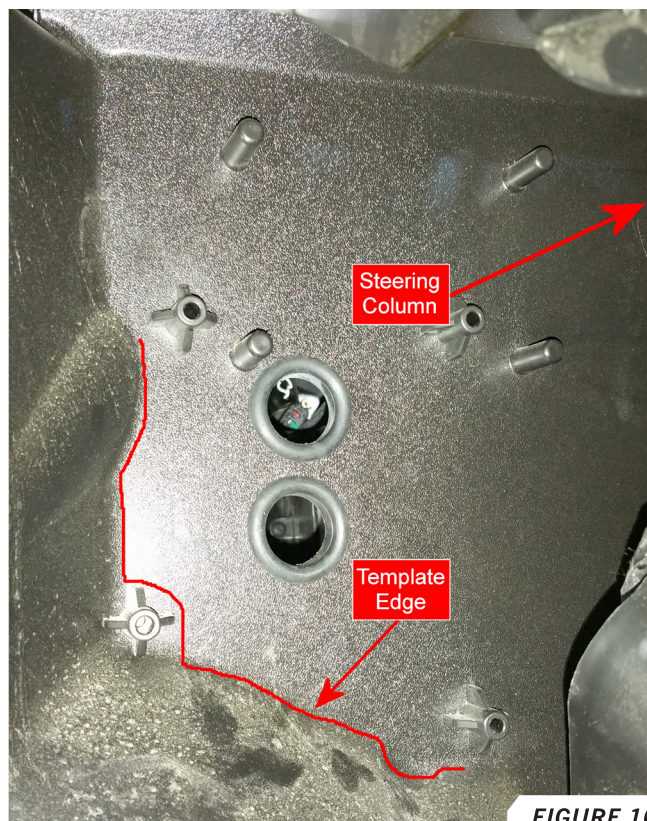

*FIGURE 10*

27. Using the pilot bit and 1¼" hole saw, drill at the marked locations. Deburr as necessary.
28. Install the two rubber grommets into the firewall.
29. Run the ⅝" hose from the rear passenger side of the vehicle, starting at the water pump (as shown in *FIGURE 11*), leaving 6–12" of slack. Follow the factory coolant lines toward the front of the vehicle.

◀ Avoid any sharp, hot, or moving parts when routing the hoses.

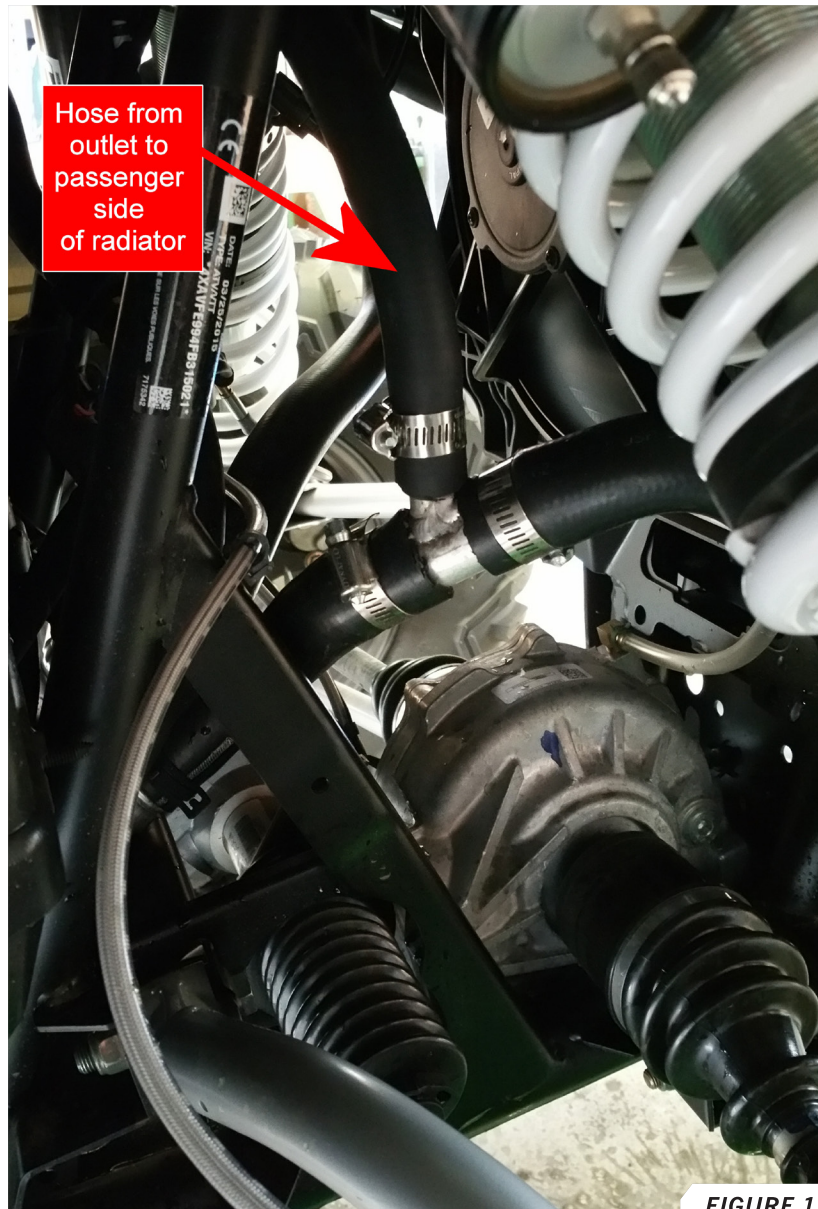

**FIGURE 11**

30. Route the hose through the area behind the radiator and toward the lower 1¼" hole drilled previously.
31. Pass the hose through the lower 1¼" hole and loop up through the opening of the front dash to the heater.
32. The ⅝" hose will attach to the inlet port of the heater, which is the bottom inlet copper pipe. Cut the ⅝" hose to length, attach it to the bottom inlet copper pipe, and secure using a #10 stainless steel hose clamp.
33. Attach the remaining length of ⅝" coolant hose to the top outlet copper pipe in the same way.

◀ Ensure the black shipping plugs are removed beforehand.

34. Route the hose through the upper 1¼" opening in the firewall, toward the passenger side of the radiator. **FIGURE 12**



35. Look down from the hood opening and locate the inlet hose (lower hose installed earlier).
36. Choose an accessible area of hose for the shut-off valve. Cut the hose, insert the shut-off valve, and secure using #10 stainless steel hose clamps.

**SWITCH WIRING**

37. Locate the 36" Wiring Harness and ensure the wires are correctly connected to the 5-Pin Black Connector as shown in **FIGURE 13** and the 4-Pin White Connector as shown in **FIGURE 14**.

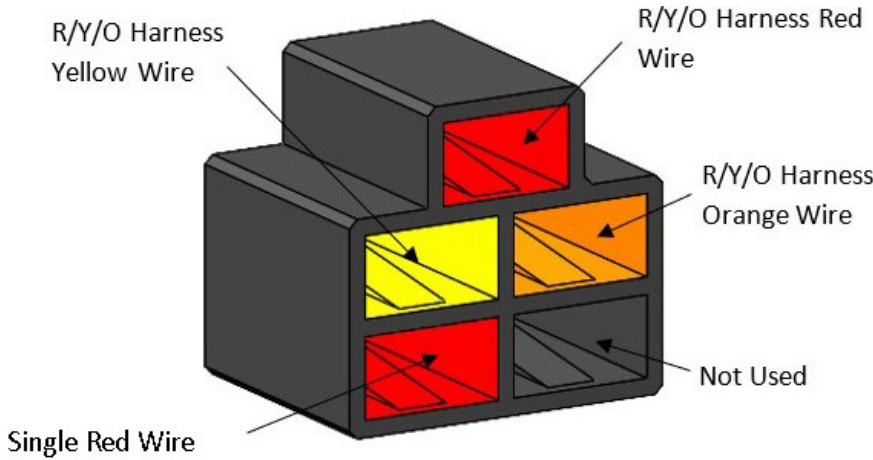

**FIGURE 13**

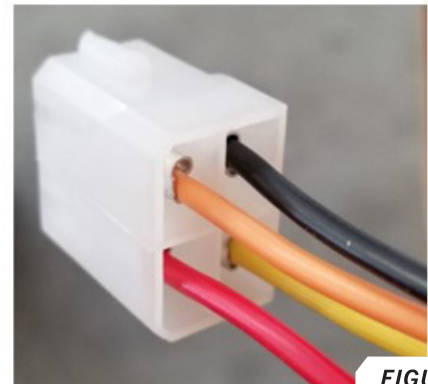
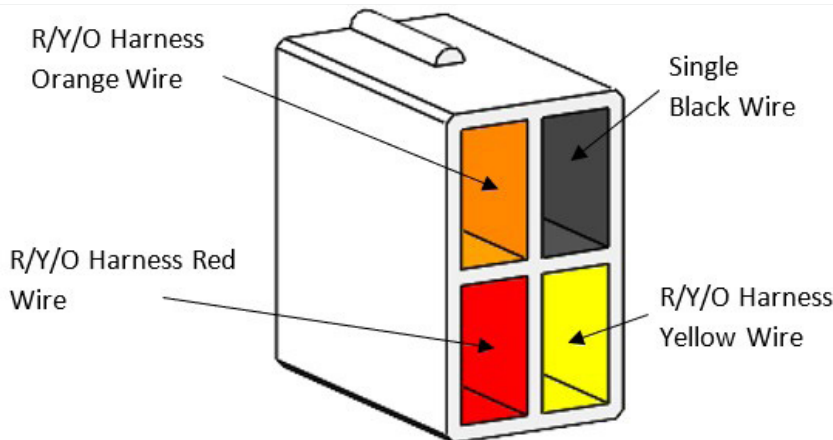

**FIGURE 14**

38. Connect the 5-Pin Black Connector to the 3-Position Switch included in the kit.
39. Position the 3-speed fan switch bezel on the center console to the right of the steering column and below the ignition switch. **FIGURE 15**
40. Once positioned in a desirable location, mark the hole center and drill a  $\frac{7}{16}$ " hole.
41. Insert the switch into the  $\frac{7}{16}$ " hole from the back of the center dash panel and secure using the low-profile hex nut included in the switch bag. Disregard the flex lock washer.



**FIGURE 15**

42. Prior to pressing the switch bezel on, use a pair of pliers to remove the two nubs on the back of the switch bezel as shown in *FIGURE 16*.
43. Place the bezel over the switch so that the 0, 1, 2, 3 markings are visible.
44. Press the switch dial onto the switch until it is seated firmly.
45. Connect the 4-Pin White Connector to the white terminal housing on the heater unit.
46. Connect the red wire to a keyed powered source (any power source that is only powered when the vehicle is on) using the terminated end. If you have no connection spot for the terminated end, cut the ring terminal off and use the insulation displacement crimps to connect the red wire to a keyed power source. This can be found by testing wires with a multimeter.



*FIGURE 16*

Common examples may include the ignition, radios, and winches, though this may vary with your vehicle.

## DEFROST VENT INSTALLATION

47. Snap the two 2" defrost vents into the holes drilled in the front dash. Press firmly and evenly along the perimeter of the vent until it snaps into place. If it does not snap, ensure that the hole has been deburred properly on both top and bottom edges.
48. Attach the two 2" defrost hoses to the 2" defrost vents and secure with zip ties.
49. Set the dash loosely into position.
50. Turn on the fan and verify that you are getting adequate air flow at each vent.

## COOLANT SETUP

51. Locate the thermostat housing as shown in *FIGURE 17*, looking from the passenger rear wheel cavity. Locate the  $\frac{1}{2}$ " hose. Remove the two hex bolts that hold the thermostat housing on and gently pull the housing away from the engine block. It is easiest to loosen the air filter box and throttle body to gain additional access.

The thermostat and gasket are floating inside the housing. Be careful not to drop them.

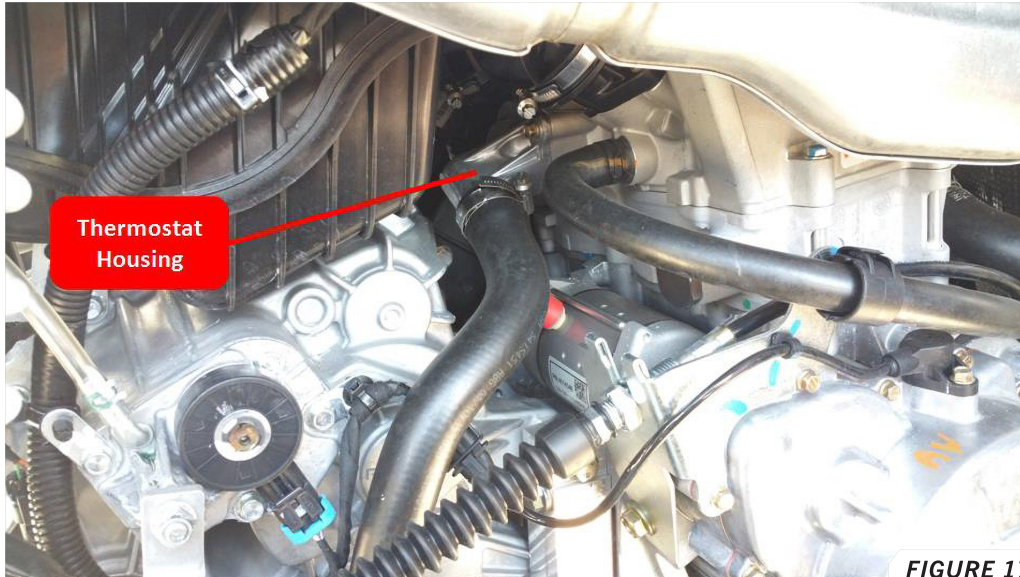

**FIGURE 17**

52. Take the included thermostat bypass valve and insert the O-ring into the cutout. Orient the bypass valve so that the  $\frac{5}{8}$ " port faces outward from the vehicle.
53. Attach the thermostat housing that was removed earlier to the thermostat bypass valve and the engine block using the included M6 hardware. Tighten to no more than 7 ft lbs.

DO NOT OVER TIGHTEN.

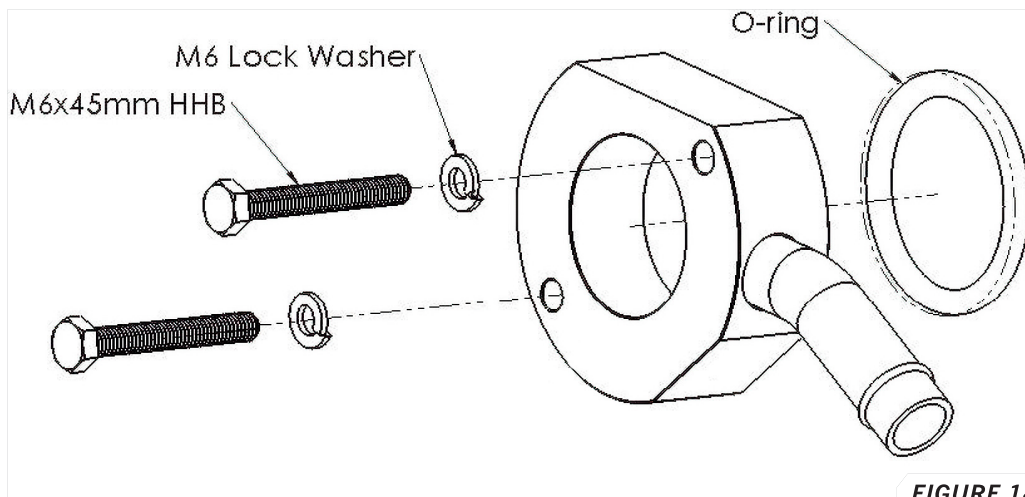

**FIGURE 18**

54. Attach the  $\frac{5}{8}$ " hose and secure it using #10 stainless steel hose clamps.

55. Locate the 1" outlet from the bottom of the radiator.

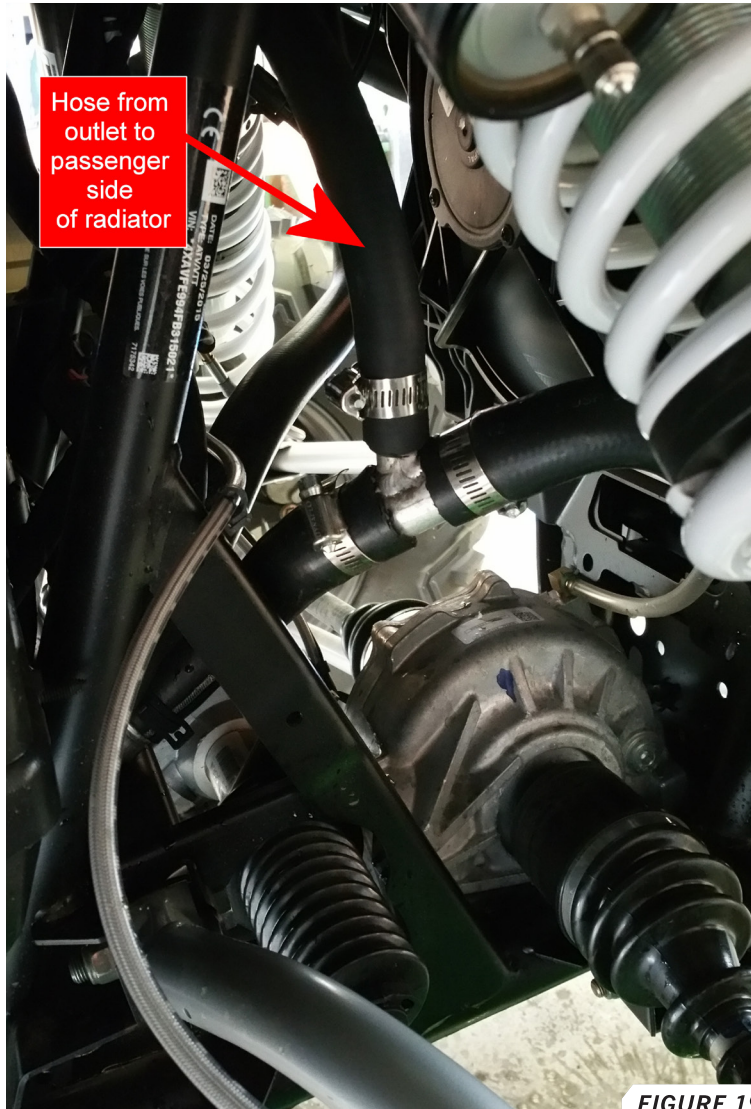

**FIGURE 19**

56. Clamp the outlet hose before and after your intended cut line.
57. Cut the 1" outlet hose at the position shown in **FIGURE 18**. The RZR Turbo may have Y fittings already in this location. The 1" aluminum Y can be placed before or after the existing attachments on the radiator.
58. Insert the 1" aluminum Y with the branch facing the radiator as shown in **FIGURE 18**.
59. Attach the  $\frac{5}{8}$ " outlet hose from the cab heater. Secure with two #16 stainless steel hose clamps and one #10 stainless steel hose clamp. Remove the clamps and verify there are no leaks.
60. Secure the  $\frac{5}{8}$ " hose with zip ties.

## BLEEDING THE COOLANT SYSTEM

Read entire section before proceeding

 Some amount of air will have made its way into the coolant system. The following bleeding procedure must be performed to eliminate the air and obtain heat. The following procedure is most easily accomplished with the help of a partner.

61. Fill radiator with coolant until radiator is full.
62. Open the shut-off valve.
63. Close the radiator cap and drive the machine around until heat comes through the vents or the machine's engine temperature goes above 200°F.
64. Turn off the machine and wait for it to cool down.
65. Open the radiator cap and add more coolant.
66. Repeat the steps in this section until consistent heat is coming out of the vents and machine temperature gauge stays under 200°F.
67. Verify that no leaks have occurred and that the radiator fluid level is per the manufacturer's specifications.

 Look at owner's manual for manufacturer-approved coolant

## FINISHING

68. Reinstall the bottom skid plate.
69. Reinstall the front dash.
70. Reinstall the front windshield as necessary.



**REPLACEMENT PARTS**

 Replacement parts can be ordered from [motoalliance.com](http://motoalliance.com). Enter the associated SKU number into the search bar to find the product.

Item Description	SKU
2" Compressed Duct Hose	HT_2inch_Compressed
2" Vent	HT_2Louvre
3" Vent	HT_4Louvre
FIRESTORM Heater Motor	RPL_HT_CU_Fan_and_Motor
3-Position Switch	HT-FanSwitch
5/8" Coolant Hose	HT_RadiatorHose_20

Item Description	SKU
1" Aluminum Y	HT_AluminumY_1
Thermostat Bypass Valve BP102	HT_BP102
Shut-Off Valve	HT_Plastic_Shut-off_Valve
Hole Saw Pilot Bit	HT_PilotBit
2" Hole Saw	HT_2_SAW
1¼" Hole Saw	HT_1.25_SAW

**Scan this QR code to see the full list of FIRESTORM replacement parts on [motoalliance.com](http://motoalliance.com)**



**Scan this QR code to get more tech help, watch troubleshooting videos, or submit a help form on [motoalliance.com](http://motoalliance.com)**





Cut Along Template Profile

Hole Center for 2" Hole Saw

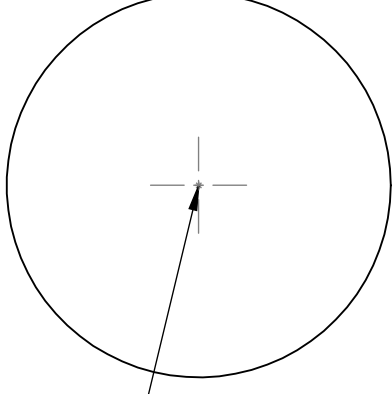

- 1) Cut along template profile
- 2) Use masking tape to attach template to dash
- 3) Mark hole center
- 4) Drill hole using 2" Hole Saw

# Template #1

## Drivers Side Template



Cut Along Template Profile

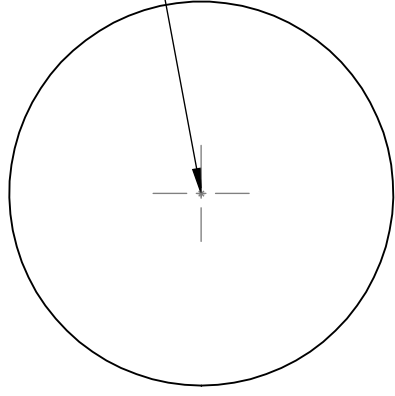

Hole Center for 2" Hole Saw

- 1) Cut along template profile
- 2) Use masking tape to attach template to dash
- 3) Mark hole center
- 4) Drill hole using 2" Hole Saw

# Template #2

## Passenger Side Template



- 1) Cut along template profile
- 2) Use masking tape to attach template to dash
- 3) Mark hole centers
- 4) Drill hole using 5/16" Drill Bit

Cut Along Template Profile

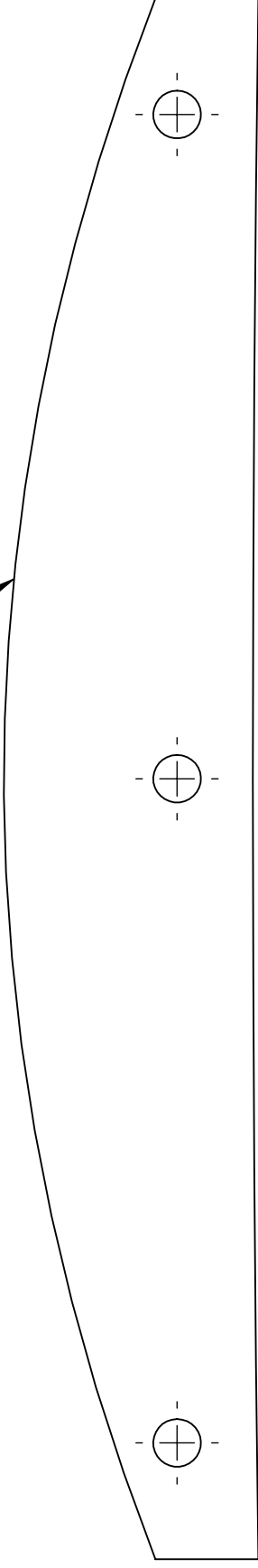

# Template #3





- 1) Cut along template profile
- 2) Position Template on firewall to the left of steering column
- 2) Mark Hole Centers
- 3) Drill using Pilot Bit and 1 1/4" Hole saw

# Template #4

